

**Village of Lexington
Planning Commission Special Meeting
Village Conference Room
7227 Huron Ave., Lexington, MI 48450
Tuesday, May 25, 2021
7 PM**

Call to Order Special Meeting: Mike Ziegler

Roll Call: Beth Grohman

Members: Ziegler Stencil McCombs Fulton
 Kaatz Picot Macksey Morris
 Huepenbecker

Approval of Agenda:

Public Comment: (3-minute limit)

Old Business

New Business

1. Consider request from the Roxbury Group for alteration to the land use permit for the Cadillac expansion.

Public Comment: (3-minute limit)

Adjournment

**VILLAGE OF LEXINGTON APPLICATION
COMMERCIAL LAND USE**

PERMIT #: 19-44
 PARCEL #:
 PERMIT FEE \$ 253.00

OWNER: CADILLAC HOUSE, LLC DATE: 11-21-19
 ADDRESS: 1117 GRISWOLD ST. STE 1416 PHONE: (586) 246-1092
DETROIT, MI 48226 CONTRACTOR: BEEH CONSTRUCTION, LLC
 BUILDING SITE ADDRESS: 5512 MAIN ST LICENSE #: 21010 72049
 Is property located within 500' of lake, stream or wetland? Yes No

PROJECT DESCRIPTION: RENOVATE EXISTING MAIN FLOOR - EVENT
ADD SECOND LEVEL - HOTEL ROOMS - 10 ROOMS

Type of Land Use Project:

- New Business
- New Building
- Addition to Building
- Accessory Building
- Alteration/Remodeling
- Parking Lot/Driveway
- Mail/Newspaper box
 - Received copy & agree to terms of ordinance

- Demolition
- Fence
- Sign(s) _____ sq. ft.
- Relocation of Building Onto Property
- Sidewalk/Cement Pad
- Sidewalk café/display
- PUD
- Mail/Newspaper Box
 - Received copy & agree to terms of ordinance
- Other _____

Zoning District:

- C-1
- C-2
- CBD
- I-1
- I-2

Siding/Exterior wallcover:

CEMENT BOARD

Estimated Project Cost

\$ 510,000.00

Occupancy Permit Granted Date

Water/Sewer Cap & Tap Fees

\$ _____

REQUIREMENTS:

SITE PLAN: Attach 1 set of building plans, and a site plan containing a survey and a diagram of proposed structure location of lot, including front, side, rear setbacks and lot lines, utilities, easements, existing buildings, sewer, water, etc.

INSPECTION: In order to verify compliance with this permit, it will be necessary for the Zoning Administrator or his/her designated agent to enter upon the premises at reasonable times until a certificate of occupancy is issued. Authorization is granted by signature.

NOTICE: The approval issued here is a zoning or land use approval, indicating this governmental unit's approval of the proposed use of the property involved. It is now mandatory that you apply for a Building Permit from the Sanilac County Department of Construction and Land Use, 61 W. Sanilac Sandusky, MI 48471. (810)648-4664. You must take a copy of this permit, and two sets of plans. The plans will be checked for code compliance before the permit is issued. Other applicable permits may be required, such as: Health Department, Electrical, Plumbing, Building (for structure only), and Mechanical (heating & cooling).

LEGAL FEES: Any and all legal fees pertaining to this application will be bore by the applicant.

DEC 20 2019
 MOON # 11749

APPROVAL INFORMATION:

CONDITIONS:

[Signature] 11-21-19
 Applicant Signature Date
[Signature] 12/11/19
 Zoning Administrator Signature Date

PAYMENT INFORMATION
 PAID CASH
 PAID CHECK CK # 11749
[Signature] 12/20/19
 REC'D. BY DATE

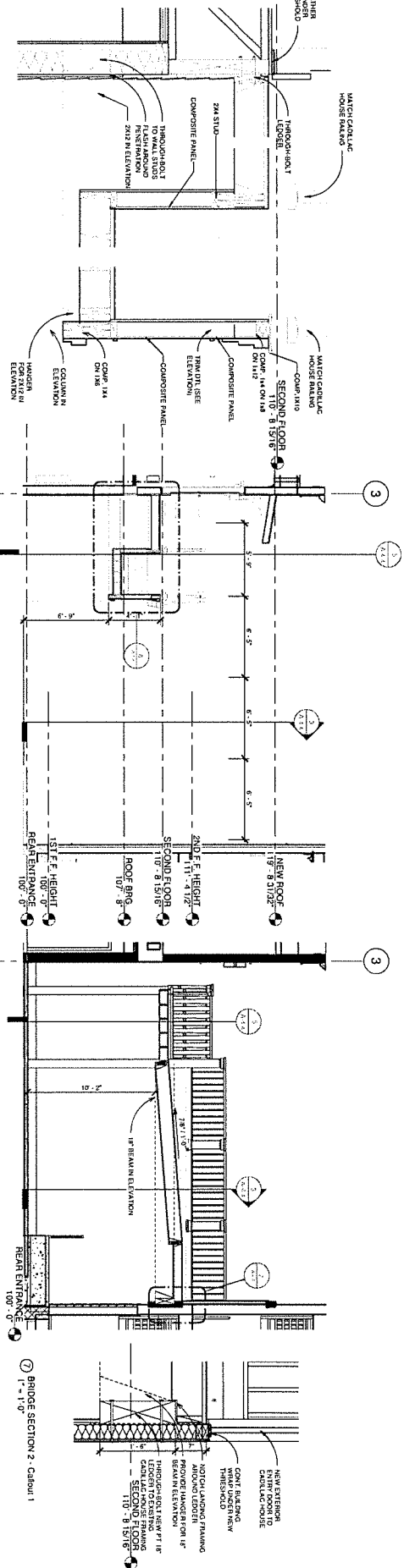

BRIDGE SECTION 1 - Callout 1
1" = 1'-0"

BRIDGE SECTION 1
1" = 1'-0"

BRIDGE SECTION 2
1" = 1'-0"

BRIDGE SECTION 2 - Callout 1
1" = 1'-0"

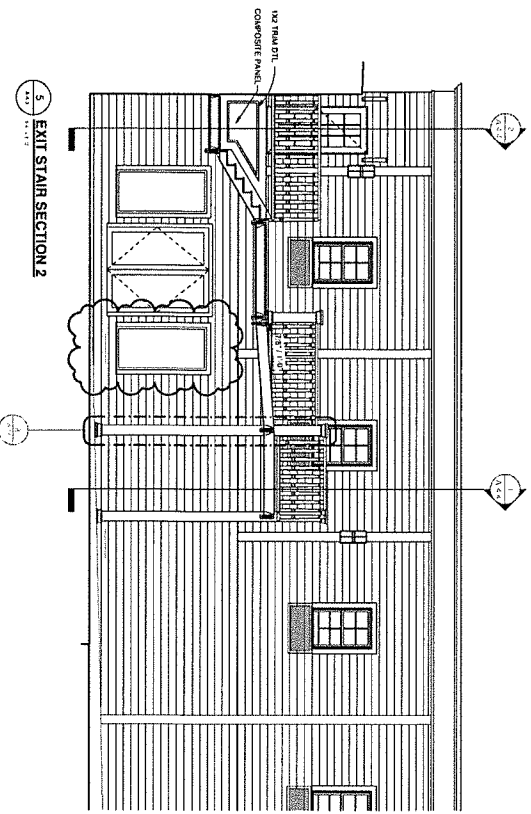

EXIT STAIR SECTION 2
1" = 1'-0"

DTL - DECK CON.
1 1/2" = 1'-0"

BRIDGE CROSS SECTION
1" = 1'-0"

BRIDGE CROSS SECTION - Callout 1
1" = 1'-0"

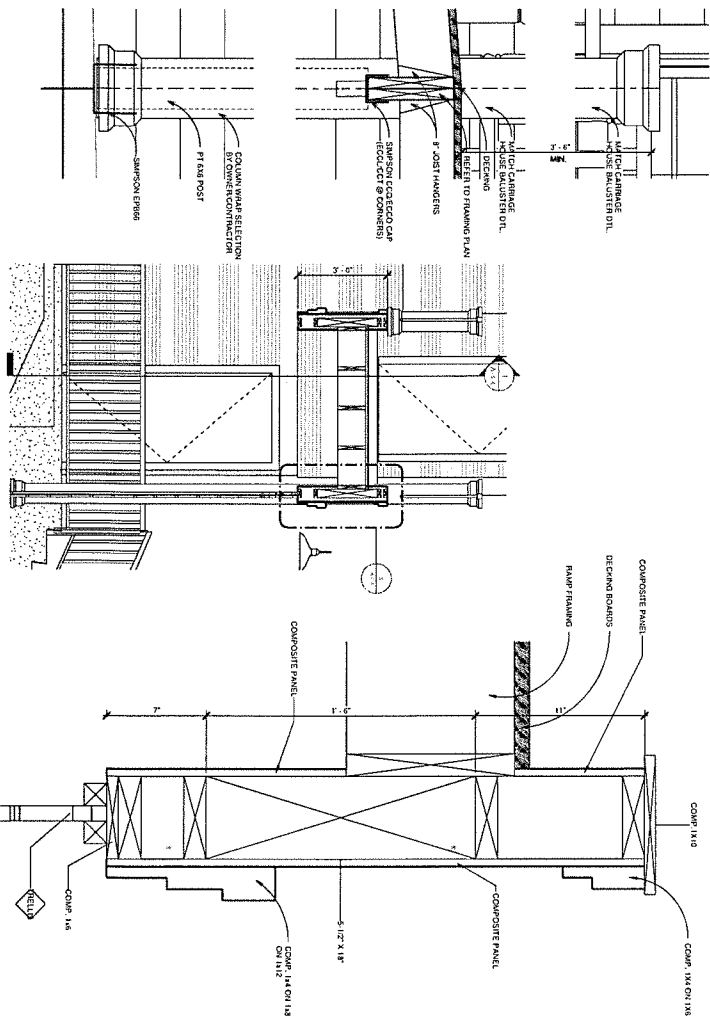

CARRIAGE HOUSE
5512 Main Street
Lexington, MI 48450
Roxbury Group
BRIDGE/ RAMP DETAILS

A-4.4

NO.	DESCRIPTION	DATE
1	ISSUED FOR PERMITS	11/22
2	ISSUED FOR PERMITS	11/22
3	ISSUED FOR PERMITS	11/22
4	ISSUED FOR PERMITS	11/22
5	ISSUED FOR PERMITS	11/22
6	ISSUED FOR PERMITS	11/22
7	ISSUED FOR PERMITS	11/22
8	ISSUED FOR PERMITS	11/22
9	ISSUED FOR PERMITS	11/22
10	ISSUED FOR PERMITS	11/22

Infuz
Architectural & Engineering
Detroit | St Clair
Phone: 810.267.8835
Email: info@infuz.com

Virtuoso
Architectural & Engineering
315.335.1288
info@virtuosodesignbuild.com